

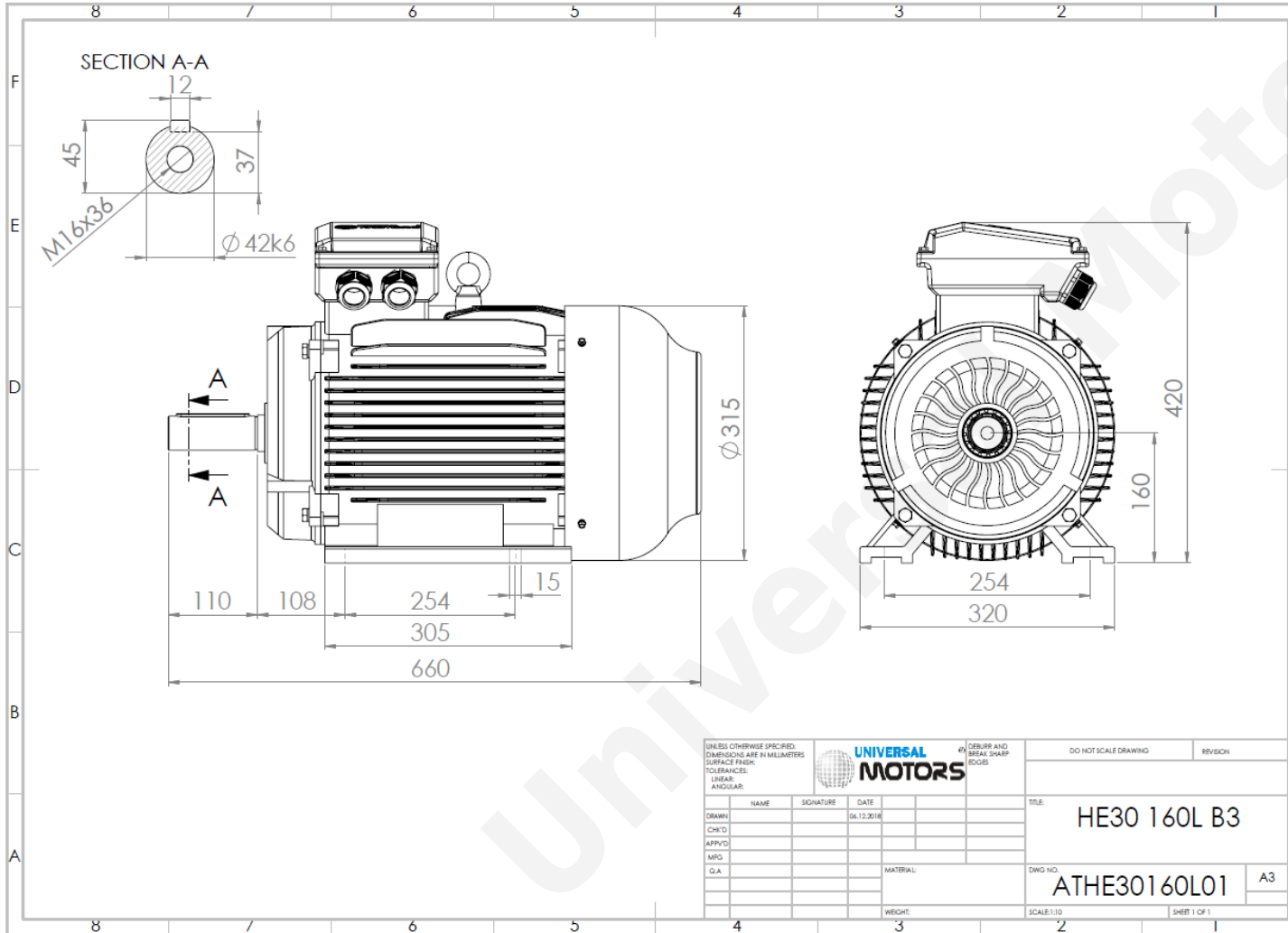

TECHNICAL DATA

Three Phase Electric Motors - Cast Iron Frame
 HE30 160 L1 2 IE2
 18.5 kW / 25 Cv
 2940 RPM



Motor type:	HE30 160 L1 2 IE2
Output:	18.5 kW / 25 Cv
Speed (min ⁻¹):	2940 RPM
Frequency:	50 Hz
Voltage:	400 V
Current:	33.0 A
Power factor (Cos Ø):	0.89
Poles:	2
Insulation class:	F
Temperature rise Class:	B
Efficiency 50%:	90.3 %
Efficiency 75%:	91.6 %
Efficiency 100%:	90.9 %
Torque:	60 N.m
Tstarting/Tnominal:	2.2
Istarting/Inominal:	8.1
Tmaximum/Tnominal:	2.3
Noise:	70 Db(A)
Weight:	153 Kg
Bearing DE:	6309 C3
Bearing NDE:	6309 C3

Regime - S1

Altitude - 1000m

Environment Temperature - 40°C

CONTACTS:

UNIVERSAL MOTORS Tel: +351 252 299 080
 Rua de São Brás,745 Fax: +351 252 299 089
 4480-782 VILA DO CONDE Mail: geral@universalmotors.pt

* References applied only in the UK